

ROCKBREAKER MECHANICAL STOP Custom Engineered Solutions

PROJECT SCOPE

Client:	Total Rockbreaking Solutions
Project:	Silvergrass Mine, Western Australia
Material:	Iron Ore Crushing Circuit
Equipment:	Rockbreaker Boom System
Model:	Rammer XL1400R and XL940R
Scope:	Design of Mechanical Slew Stops
Aim:	Provide a mechanical slew limit in the event of an electrical limit switch failure.

As the engineering service provider for Total Rockbreaking Solutions, Bulk Handling Technologies (BHT) was requested to design mechanical slew stops for two (2) large rockbreaker boom systems destined for RTIO at their Silvergrass operations. The fixed pedestal rockbreakers were fitted with large diameter slew bearings and were driven via twin hydraulic drives which could rotate through a full 360 degrees.

To safeguard operators, mechanical stops were required to ensure that, in the event of a slew limit sensor failure, the rockbreaker would be prevented from impacting the control cabin or entering other areas where personnel might be working.

DESIGN CHALLENGES AND CONSIDERATIONS

With a total mass over 12t for the larger XL1400R and a reach of 14m, the biggest challenge was dissipating the kinetic energy and decelerating the mass in the shortest possible time without over-stressing the components.

Additionally, it was a requirement that the new mechanical stops be designed as an integral part of the slew base, without imparting any direct loads to the supporting structure.

Mounting the mechanical stops to the fixed base provided further challenges as it was desirable to avoid welding to the base where possible and also ensure the design did not restrict access to slew bearing bolts with a hydraulic torque wrench during maintenance activities.

THE FINAL SOLUTION

The final design incorporated heavy, high tensile support brackets, bolted to the existing flanges. The brackets supported large, energy absorbing rubber buffers which could decelerate the entire boom assembly from full speed to a stop with less than 50mm of compression. To allow for fine adjustment during commissioning, packers behind the rubber buffer can be added or removed independently on each side.

The mechanical stops were assembled and tested at Total Rockbreaking Solutions premises in Perth to confirm conformance to design. The final system achieved a stopping angle of 3 degrees from full speed to rest, which was well within the requirements specified by the customer.

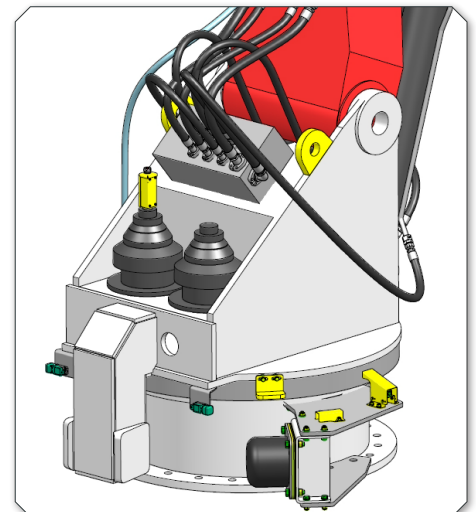

For more information on this project, or any other enquiries, contact us + 61 (0)8 9332 3454 or sales@bhtgroup.com.au